



Air Products CRYO-DIP™ uses the liquid nitrogen immersion freezer to produce high quality IQF product. CRYO-DIP can achieve a through-put of 2-5 tonnes/hr depending on product freezing characteristics. This performance is coupled with low capital cost and a low space requirement.

*IQF = Individually Quick Frozen

EQUIPMENT AND PROCESS

The CRYO-DIP™ freezer is essentially an efficiently insulated box, fabricated from food grade stainless steel. Food products are conveyed and allowed to drop directly into liquid nitrogen at -196°C . The liquid nitrogen is maintained at a constant level and automatically supplied from an outside tank using a microprocessor control system. A conveyer lifts the IQF product from the liquid nitrogen ready for packaging or further processing.

PRODUCTION FLEXIBILITY

The CRYO-DIP is capable of freezing up to 5 tonnes/hr depending on the product. The running costs of the dip are directly proportional to the product throughput. This high economic turndown makes CRYO-DIP ideal for both seasonal and regular production.

LOW INVESTMENT

The low capital investment required for a CRYO-DIP allows easy entry into IQF products. Space savings are archived as a CRYO-DIP unit requires less than 3.5 m² of floor space. Installation and commissioning take place in less than a week and labour, maintenance and spare part costs are all low.

PRODUCT QUALITY

Immersion in liquid nitrogen at -196°C freezes the surface of the product instantaneously. This prevents moisture loss and fixes flavour, weight and texture resulting in IQF product of the highest quality.

COMPATIBILITY

The CRYO-DIP is manufactured in three different widths which ensures a good fit with existing production lines. Air Products also produce a range of CRYO-QUICK™ freezing tunnels which can be matched with CRYO-DIP to maximise the efficiency and capacity of your IQF operations.

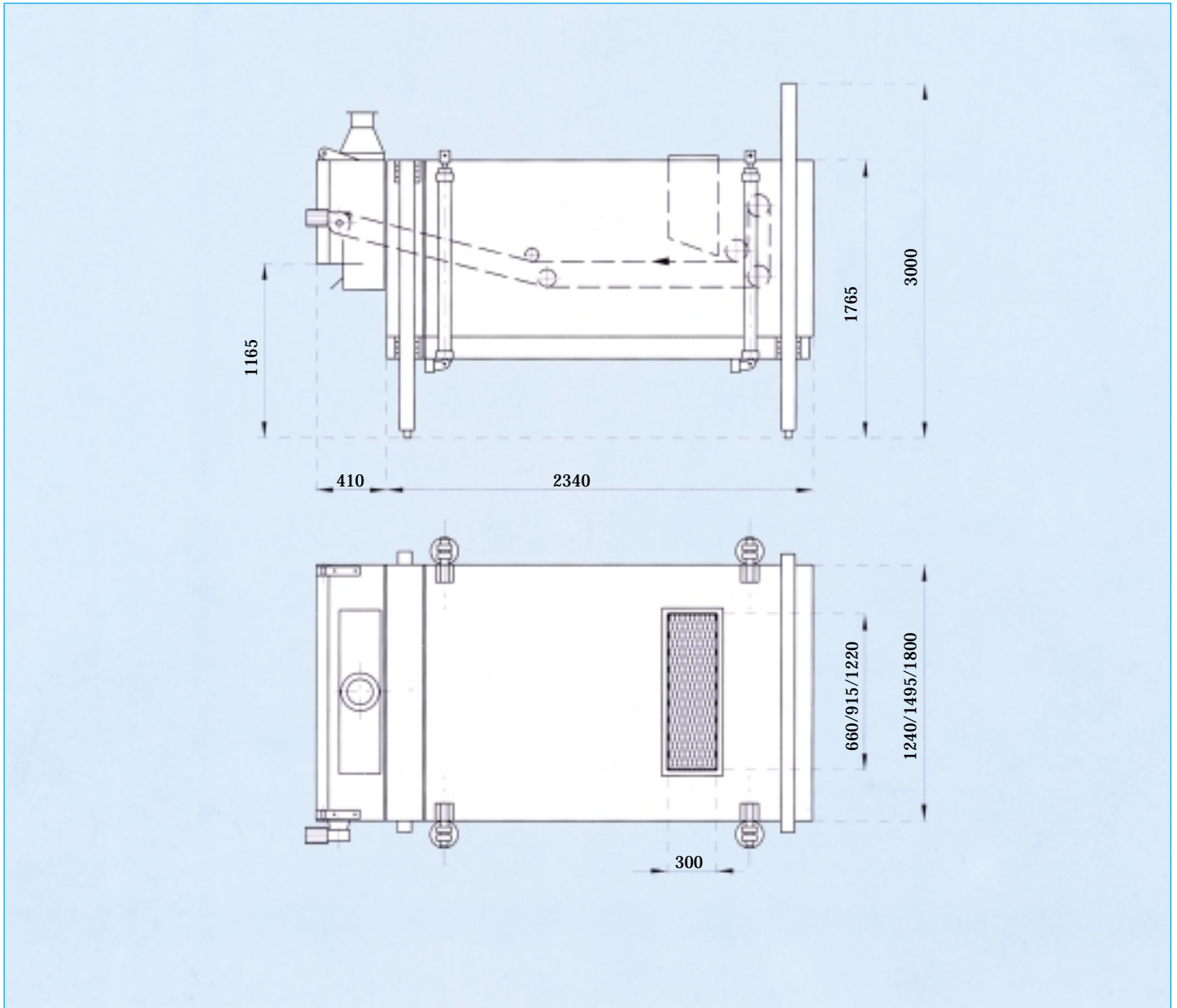

MODEL NUMBER	USABLE WIDTH	O'ALL MACHINE WIDTH	O'ALL MACHINE LENGTH	INLET HEIGHT	REQUIRED 3 PHASE ELECTRICITY SUPPLY	APPROXIMATE WEIGHT
	m	m	m	m	kW	kg
CD 660	0,660	1,485	2,750	1,640	8	1300
CD 915	0,915	1,680	2,750	1,640	8	1600
CD 1220	1,220	1,975	2,750	1,640	8	1930

AIR PRODUCTS PLC

Food Group
 1 Millennium Gate
 Westmere Drive
 Crewe CW1 6JA
 Tel.: 0800 44 12 70
 Fax: 01270 50 65 17